

# T1 Network Technology



Essentials for Successful Field Service Technicians

T1 Testing: Technology and Applications

COMPUTING

COMMUNICATIONS

VIDEO

## T1 Network Technology

► Primer

### Introduction

The public wireless telephony business has gone through revolutionary changes since its large-scale commercial introduction in the early 1980's. The service has evolved from analog systems to digital systems, and usage has expanded exponentially. The number of wireless network service providers has correspondingly expanded, as have consumer choices for their providers. In order to retain customers, communications network service providers are focusing on the quality of their network as a means of providing customer satisfaction and reducing churn. At the same time, wireless network operators are focussing on efficiency – increasing revenue while maintaining or lowering operating expenses.

The stakes are high. Network systems must perform reliably in the face of fierce competition – success or failure is directly dependent on customer satisfaction. Customer loyalty waivers with each dropped call or the next advertised service special.

In wireless telecommunications systems, the Base Transceiver Station (BTS) provides the key link between the consumer and the network. The link between the BTS and the Mobile Switching Center (MSC) is equally key in providing the connections between the nodes of the network. These "backhaul" links are generally based on wireline T1 technology.

T1 links can easily be classified as a "commodity" technology. However, BTS technicians are often more familiar with RF measurements and test equipment, and are not always widely experienced in troubleshooting T1 problems. In addition, wireless network operators often lease their T1 links from "wireline" telephone company (Telco) service providers. Identifying and troubleshooting problems can also require a collaborative effort between the BTS technicians and the Telco technicians. All of this leads to the importance of having advanced, easy-to-operate test tools in the hands of the people tasked with maintaining the wireless network.

This primer, along with its companion application note, "Troubleshooting T1 Lines with the NetTek YBT1 Circuit Tester" addresses the most common measurement challenges faced by technicians who maintain BTS stations' wireline connections to the MSC. We begin with an overview of T1 technology, followed by a description of common T1 network topologies, and then introduce some key T1 measurement principles. The application note provides insight into troubleshooting some common problems seen on the backhaul lines in wireless networks.

### T1 Technology

This section is a reasonably detailed overview of the basic principles of T1. You can use this as reference information to improve your understanding of how the technology is used. However, you do *not* need to be an expert

at T1 technology to effectively troubleshoot T1 problems. The sections following this one are intended to aid you in being more effective in maintenance and troubleshooting.

You may notice throughout this primer that the terms T1 and DS1 are used somewhat interchangeably. This is by adopted convention of the telecom industry. Technically, however, there are different definitions for the DS1 and T1 terms. A DS1 – digital signal, level 1 – is a channel that carries data at 1.544 Mbps. It may be channelized, as in T1 or an unchannelized serial data stream, as in Frame Relay. A DS1 that is channelized into 24 digital voice/data channels, each channel at 64 kbps (called a DS0 – digital signal, level 0), is known as a T1 carrier<sup>1</sup>.

You may also find that throughout this document, T1 / DS1 circuits are referred to as T1 circuits, lines, links, spans, backhauls, or backhaul lines. These terms are common parlance in the telecomm industry and are used fairly interchangeably. "Backhaul" is more commonly referring to lines carrying signals from the Base Transceiver Station (BTS) sites "back" to the Mobile Switching Center (MSC) in the networks of wireless operators, the target audience for this application note.

In the DS1/T1 system, two pairs of copper wires are used. One twisted-pair set carries data in one direction (the transmit side, or side 1), and the other pair, usually in a separate binder group, carries data in the opposite direction (the receive side, or side 2). T1 transmission is inherently a digital signal. The transmitted 1's and 0's correspond to either digitized voice or data signals. Historically, T1 (also known as T-carrier) transmission was designed around the need to transmit large quantities of voice traffic within the wired telephony networks. More recently, needs for data transmission has equaled the need for transmission of voice traffic.

### Pulse Code Modulation and Time Division Multiplexing

To transmit voice over a digital channel, the analog voice signal needs to be sampled and digitized. The human voice can be sufficiently characterized within a bandwidth of approximately 300 Hz to 3.4 kHz. Shannon's sampling theory states that the original signal can be successfully reproduced provided the sampling frequency is at least twice the signal bandwidth. Therefore, the basic sampling rate for voice communications was chosen to be 8000 samples per second, or 8 kHz. In Pulse Code Modulation (PCM) systems, the height of each sampled pulse is assigned a coded value to represent its value, as shown in Figure 1. This figure shows a linear coding scheme, where amplitude values are linearly assigned bit values – a linearly increasing signal will produce a linearly increasing code value.

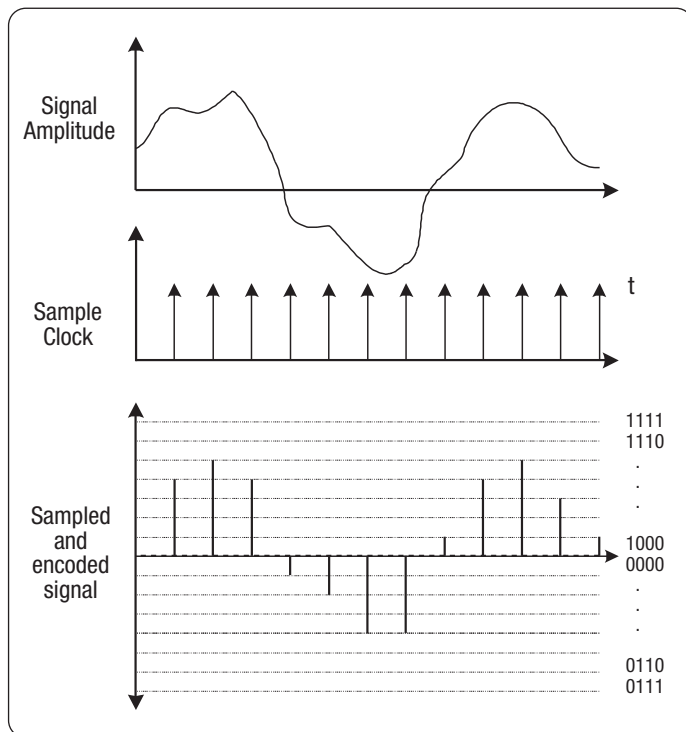

▶ **Figure 1: Sampling and PCM coding**

However, in order to keep the transmission bit rate to a minimum, the number of bits required for encoding must also be kept to a minimum. But limiting the number of bits used in the encoding limits the fidelity of the reproduced signal. So a non-linear coding scheme was devised that allows faithful reproduction of the original signal using only 8 bits. In North America, this scheme is  $\mu$ -law ("Mu-law") encoding. It is also a form of pulse code modulation, or PCM.

A DS0 is a channel that transports customer information at 64 kb/s. Now you can understand where that rate came from: (8 bits for PCM encoding) x (8k samples/sec for sampling voice) = 64 kb/s. In T1 systems, there are 24 individual 8-bit DS0 samples grouped together into a frame, where each DS0 sample is assigned its own "time slot." The process of assigning channels to a time slot within a data stream is called Time Division Multiplexing, or TDM. This is explained in a bit more detail in the section on T1 framing.

### The DS1 Signal

DS1 data is transmitted in digital format; that is, it is transmitted in the form of 1's and 0's. As the transmitted signal progresses down a cable, it degenerates due to losses in the cable. At the same time, noise from outside sources, such as adjacent cables, can couple onto the transmitted signal. To compensate for these negative effects, regenerative repeaters are deployed in the circuit to sample and recreate the original signal at periodic intervals along the link. Receivers (regenerators, NIUs, etc.) need to be able to recover the transmitted signal and distinguish the signal from the noise. In addition, they need to derive the sampling clock from the incoming signal. For these reasons, and a few others having to do with transmitting digital signals over copper wire cables, T1 links use line coding.

### AMI Line Coding

The line coding used by T1 signals is called Alternate Mark Inversion (AMI). In this scheme, ones (also called "Marks") are transmitted in the shape of a pulse with a nominal amplitude of 3 volts, and zeros (also called "spaces") are transmitted with no pulse – as a straight line or zero volts. The AMI signal is bipolar – each subsequent mark is transmitted in the opposite polarity from the last one. So a data pattern of 11001 would be a signal with the shape of +3v, -3v, 0v, 0v, +3v, as shown in Figure 2.

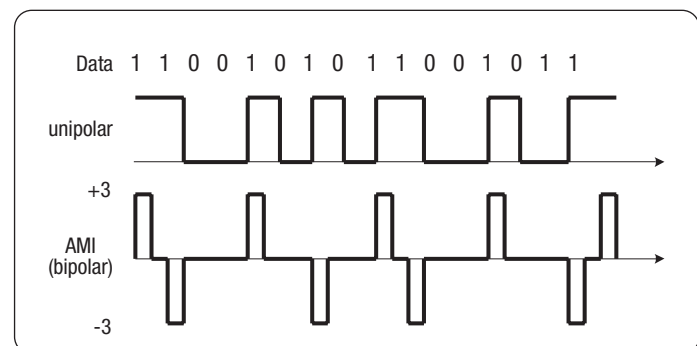

▶ **Figure 2: AMI line coding**

There are a couple of advantages to this transmission coding. The bipolar signals allow for longer transmission distances over copper cable, as compared to unipolar transmission. In addition, the bipolar format provides a certain level of noise immunity – consecutive pulses with the same polarity constitute a "bipolar violation" or BPV. A BPV indicates that the signal has been corrupted by an external influence, like crosstalk from adjacent cables, or perhaps from a lightning strike somewhere in the system.

## T1 Network Technology

► Primer

### B8ZS Line Coding

The receivers in T1 systems need to recover the sample clock from the transmitted signal so that they can correctly recover the signal itself – they have to know when to sample the signal so they can determine if the incoming bit is a one or a zero. Receiver systems recover the clock by detecting the transitions on the signal, and locking an internal timing reference to those transitions. In this way, they maintain synchronization with the rest of the network and the clock that was used to transmit the signal. However, in order for this scheme to work, the receiver must see a sufficient number of transitions on the incoming signal. If it does not, it cannot maintain a lock on its clocking, and data may get sampled incorrectly, which can cause bit errors. Several methods have been devised to prevent this from happening.

Since zeros in the data stream result in no transitions on the transmitted signal, the devised methods all involve limiting the number of consecutive zeros that can be transmitted. All DS1 signals must meet specific requirements for ones density – a measure of the number of ones in relation to the total number of bit time slots transmitted. For DS1, a ones density of 12.5 percent must be maintained, on average, within a frame, or one mark for every seven zeros. Also, no more than 15 consecutive zeros can be transmitted in succession.

One of the most common methods used in T1 systems to maintain ones density is known as binary 8-zero substitution, or B8ZS. For the B8ZS scheme, any time eight consecutive zeros are detected in the data stream to be transmitted, the transmitter "substitutes" a fixed pattern of ones, zeros, and BPVs in place of those 8 zeros. This is a very specific pattern; each block of eight consecutive zeros is replaced with 000VBOVB, where B represents an inserted "1" bit, and V represents an inserted "1" that is a bipolar violation<sup>III</sup>. Refer to Figure 3 to see how this works. Since this is a known pattern, the terminating receivers (line cards, CSUs, network muxes) can recognize this pattern and re-substitute the original string of 8 zeros back in place of the fixed pattern.

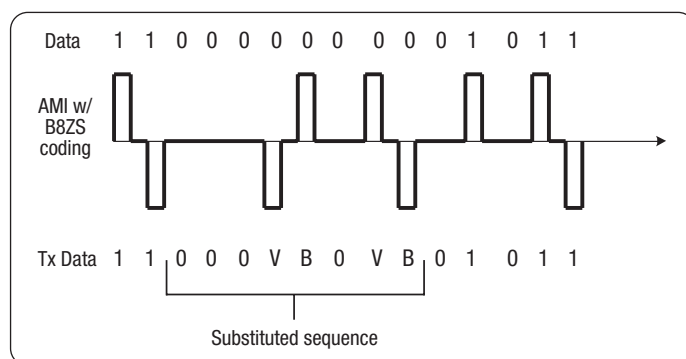

► Figure 3: Bipolar 8 zero substitution (B8SZ)

It is very important to note that B8ZS coding is imposed on an AMI line code. So B8ZS is actually an AMI encoded circuit that has the addition of a unique code whenever the transmitted signal contains eight zeros in a row. So, a B8ZS circuit will appear to be provisioned for AMI unless the data signal meets the eight consecutive zeros requirement. In other words, you have to have enough zeros in a row (eight) for the B8ZS pattern to be substituted, and for equipment to recognize that the line is actually provisioned for B8ZS. It all depends upon the data being transmitted whether the B8ZS substitution pattern actually needs to be inserted, and whether it will be detected by test equipment.

### The T1 Frame and Why 1.544Mbps

The digitized voice signal and the data signals are collected together into a framed structure for transmission, as mentioned. Each individual signal, or DS0, is assigned its own time slot within the frame. This process is known as Time Division Multiplexing (TDM). The TDM employed in T1 communications divides the frame into 24 timeslots, and adds one framing bit, as shown in Figure 4.

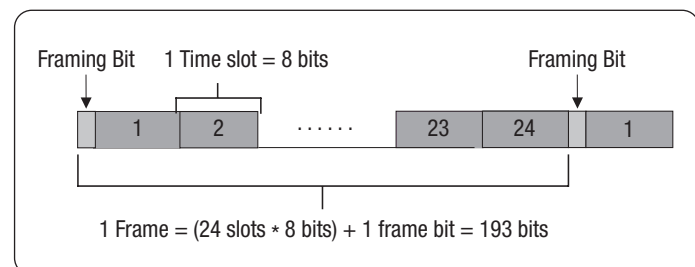

► Figure 4: The T1 frame

So each timeslot, or DS0, contains 8 bits of information. There are 24 DS0 timeslots in one T1 frame, giving us (24 \* 8) 192 bits of data. Each frame also has a framing bit preceding the DS0s, giving a total of 193 bits of data per frame. Since we need to transmit each DS0 8000 times per second (because it was sampled at 8,000 samples per second), the frame transmission rate must be 8,000 frames per second. This results in a total data rate of :

$$193 \text{ bits/frame} * 8,000 \text{ frames/sec} = 1.544 \text{ Mbps.}$$

This data rate signal is also known as a DS1. Within the DS1, there is 1.536 Mbps of user data, or "payload" data in the DS0 time slots and 8 kbps of framing information<sup>IV</sup>.

**T1 Framing Formats**

A T1 frame by itself is indistinguishable from the next frame. From the receiver's standpoint, looking at a stream of received bits, any one of the incoming bits *could* be the framing bit. So to allow the receivers the ability to identify the framing bits, multiple frames are concatenated together, and the framing bits are transmitted as a specific "framing pattern" of ones and zeros. Taking a somewhat simplified view, now the receivers only have to look for the framing pattern every 193rd bit in the data stream. Once they find the framing pattern in consecutive framing bits (with some more complex criteria), the framing is declared to be "in sync." Again, this is a simplified view of a complex framing synchronization process, but it should give you an understanding of why framing formats are used.

So the concatenated frames employing framing patterns in the transmitted framing bits are known as framing formats. There are several different types of framing formats used in T1 communications. Each type of framing format has its own benefits, and use is dependent upon the application. In the links used to connect the wireless network nodes together, however, there are two prevalent types of framing formats. D4 framing, otherwise known as Superframe format, and Extended Superframe Format, otherwise known as ESF.

**Superframe (D4) Framing**

A D4 Superframe consists of twelve consecutive frames, as shown in Figure 5. The D4 Superframe format is a structure in which the F (frame) bits are used for framing alignment only. In this format, the F bits are actually divided into two groups (refer to Table 1)<sup>V</sup>. The odd bits are called the terminal framing bits, or  $F_T$  bits, and are used exclusively to identify frame boundaries. The even-numbered bits are called the signaling framing,

or  $F_S$  bits, and may be used to identify frames that carry signaling. However, it is beyond the scope of this application note to discuss signaling formats used in D4 framing – the T1s connected in wireless network operator backhauls are typically not provisioned for signaling such as robbed-bit signaling. The framing bits comprise an 8 kbps (8000 frames per second) overhead channel that cannot be used for transmitting user data.

It is important to note that in D4 framing, though, maintenance signals such as network alarms and codes are sent "in-band" meaning that they can overwrite user data in the DS0s. Since the duration of these codes is usually short, typically this does not adversely affect voice or data traffic. However, in certain applications, maintenance signaling could be intrusive and can impact quality of service. For this reason, different framing methods were devised that can provide maintenance signaling without over-writing user data.

**Table 1: D4 Superframe Format**

Frame number	Superframe bit number	$F_T$ bit	$F_S$ bit
1	0	1	-
2	193	-	0
3	386	0	-
4	579	-	0
5	772	1	-
6	965	-	1
7	1158	0	-
8	1351	-	1
9	1544	1	-
10	1737	-	1
11	1930	0	-
12	2123	-	0

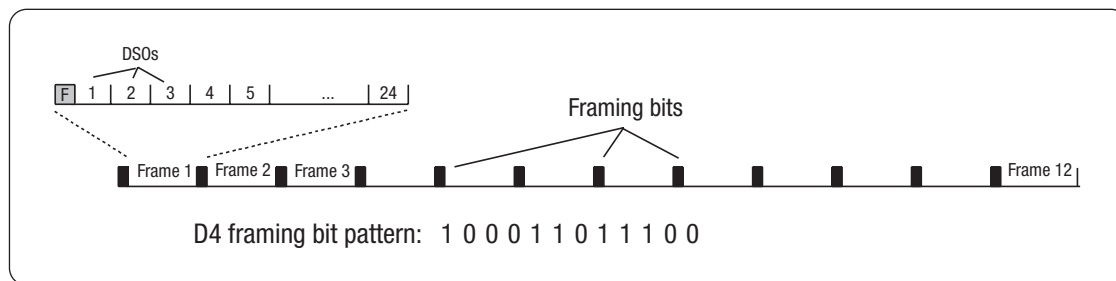

▶ **Figure 5: D4 Framing**

## T1 Network Technology

► Primer

### Extended Superframe Format (ESF) Framing

An extended Superframe consists of twenty-four consecutive frames, as shown in Figure 6. The ESF format uses twice as many frames as the D4 format. But rather than simply doubling the number of bits used for maintaining frame alignment, the framing bits are separated into three categories. These provide capabilities that D4 framing does not have, allowing messages to be sent out-of-band so customer data is not overwritten, and equally important, providing a quality monitoring channel that allows monitoring network performance without taking the network out of service.

The three channels contained in the ESF framing bits are V:

The **Framing Pattern Sequence (FPS)** bits, which make up a 2 kbps channel, are used exclusively for maintaining frame alignment and indicating which frames may be used for signaling. As shown in Figure 6, the framing pattern bit sequence is 001011. ESF framing provides for enhanced signaling capabilities, but this area is beyond the scope of this application note.

The 2 kbps **Cyclic Redundancy Check (CRC)** channel bits carry a CRC-6 code. This is a field used to detect errors in blocks of data. It allows detection of bit errors in the transmitted data stream with about 98 percent accuracy. The CRC is calculated on a block of data (the previous 24 frames) and then the code word is sent in the next frame. The receiver makes the

identical calculation on the incoming data, then compares this with the received CRC-6 code. If the codes match, then there were likely no bit errors in the previous block (ESF frame) of data. If they don't match, then a CRC error is declared, indicating at least one error received in the previous block of data. In this way, the equipment can estimate the bit error rate without having to take the link out of service, insert a known data pattern, and make an explicit BER measurement.

The **Facility Data Link (FDL)** bits comprise a 4 kbps channel that is used for communicating maintenance signaling information such as performance information (Performance Report Messages, or PRMs) and control signals (network messages defined in the T1.403 standard) across the network. This link can be used for sending "out-of-band" maintenance signals to network equipment, such as loop codes, alarms codes, and protection switching, all without compromising user traffic in the DS0 channels. ESF framing also can support the use of in-band maintenance signals as are used in D4 framing. The FDL messages may be organized either as bit-patterned messages containing 16-bit codewords, or message-oriented signals encapsulated in a format such as LAPD protocol. When idle, the FDL channel contains continuous repetition of 01111110.

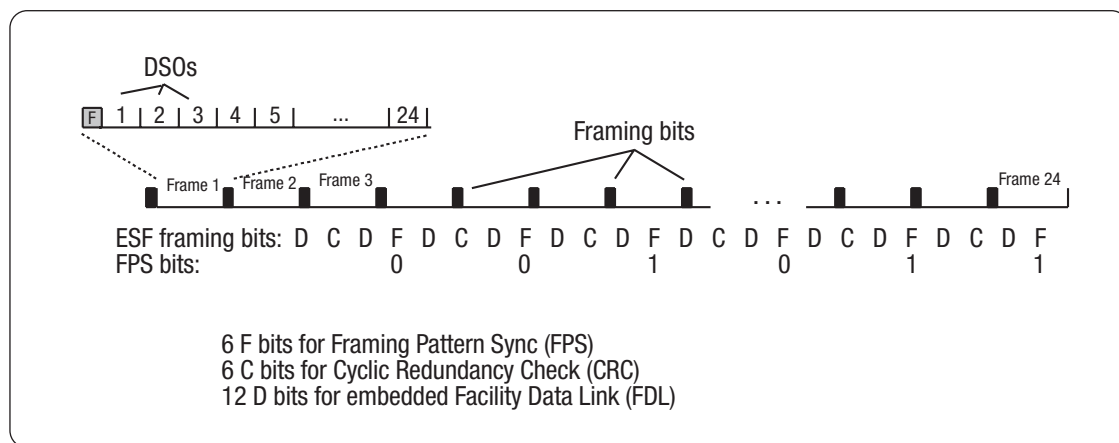

► **Figure 6:** ESF framing format

**Common T1 Network Topologies for Wireless Operators**

There are typically three or four basic components of the backhaul networks employed by wireless network operators. These are the Base Transceiver Station (BTS), the Base Station Controller (BSC) which is often co-located in the BTS, the Mobile Switching Center (MSC), and the Public Switched Telephone Network (PSTN) also referred to simply as "the network." You can see how these might be connected in Figure 7.

T1 circuits can actually take several different physical forms for wireless backhaul networks. Copper pair is usually the most prevalent in this application, however newer installations may use fiber, and remote locations may use microwave relays. Circuit configurations vary depending upon region, network operators, and base station location. Figure 8 shows several alternate circuit topologies. These are by no means complete examples, but they offer a view of how the circuits can vary simply from one BTS connection to the next.

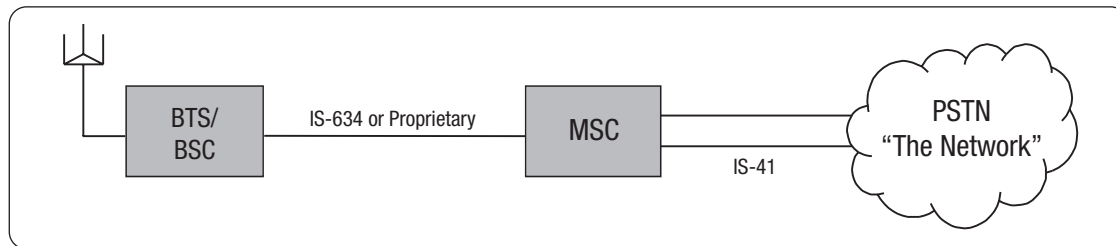

► **Figure 7:** Typical backhaul network

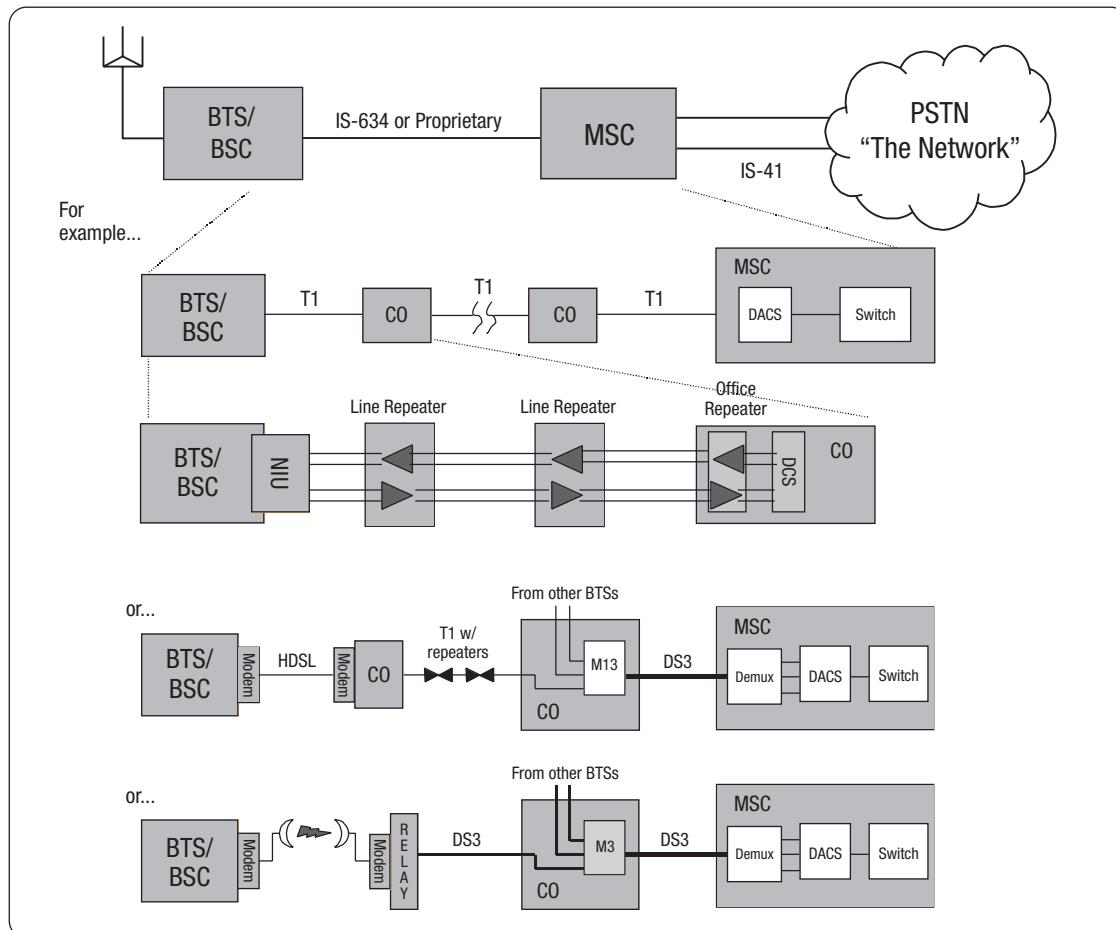

► **Figure 8:** Some T1 backhaul examples

## T1 Network Technology

### ► Primer

In most cases for wireless network operators, the T1 links themselves are leased from the local telephone company providers (Telcos), and the Telcos are responsible for servicing and maintaining these T1 links. The BTS and the MSC contain what is referred to as Customer Premises Equipment, or CPE. It is the responsibility of the customers, the wireless network operators in this case, to service and maintain the CPE. The Telco networks have a point of demarcation between their network and the CPE. At the BTS, this demarcation point is the Network Interface Unit, or NIU. All of these different backhaul circuit configurations have one thing in common: inside the BTS, the connection to the BTS controller itself is nearly always a T1-configured signal. Installations within the base station also vary by network operator, but a common configuration is shown in Figure 9. Each element is also described below.

### NIU

Located between the T1 line and the CSU, the Network Interface Unit (NIU) is considered the demarcation point between the network and the customer premises. The primary functions of the NIU are to provide signal regeneration, DC isolation from the network to the customer premise, and loopback capabilities for network testing. It is often referred to as a "smartjack" because it

provides loopback capabilities and can collect and return performance data to the Telco Central Office. The NIU may also incorporate some of the functions found in the CSU (described below) which enhance carrier maintenance operations by allowing the carrier remotely to sectionalize problems. Finally, the NIU loops the span current, used to power the repeaters in the span, back to the CO.

### DSX

The Digital Cross-connect (DSX) panel is a manual cross-connect point that primarily serves as a test access point for DS1 signals and for substituting operational equipment when necessary. This is where technicians will usually connect their T1 test sets to verify the functioning of the T1 link. Using the connections at the monitor ports, the technician can:

- Monitor what the BTS line card is transmitting toward the CSU / Network
- Monitor what the CSU is transmitting towards the BTS line card
- Monitor what the CSU is transmitting towards the NIU / Network
- Monitor what the Network (BSC) is transmitting towards the CSU / BTS

Please refer also to page 14, "The Simplified DSX-1 Patch Panel" for more details on DSX-1 operation.

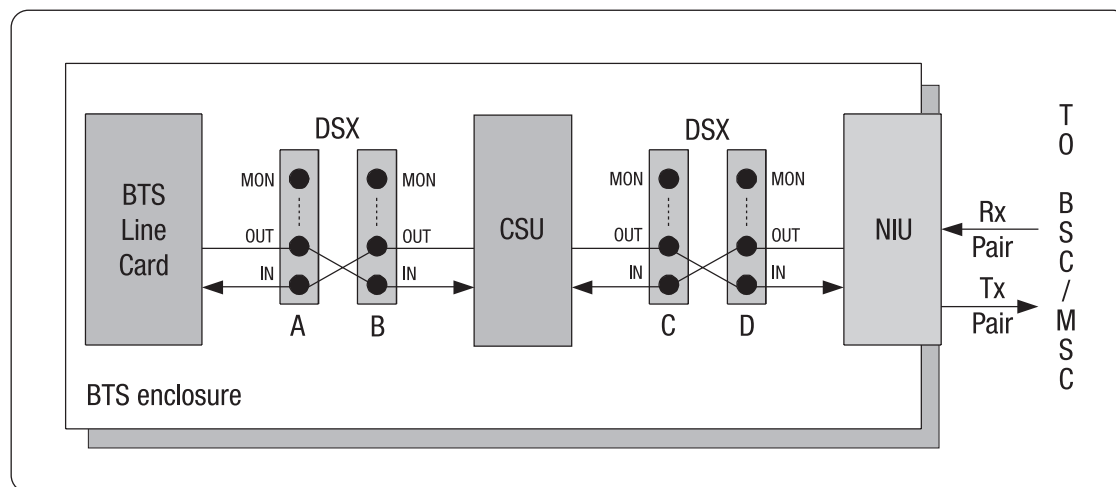

► **Figure 9:** Example T1 connections at the BTS



### CSU

The Channel / Data Service Unit (CSU / DSU) provides framing, coding, and facility equalization functions, as well as performance monitoring and history reports on the T1 links in both transmit and receive directions. The CSU connects customer equipment (the BTS line card) to the Telco's digital transmission equipment (the NIU) and is responsible for maintaining a high-quality, synchronized signal at either interface. The CSU has the following functions:

- Provides loopback functions that permit testing of the entire circuit from one location.
- Provides alarm generation if the terminating equipment (BTS line card) fails or becomes disconnected. This keeps the network from losing synchronization.
- Provides T1 access and monitoring for both line and terminating equipment (although this is more commonly done at a DSX panel).
- Performance monitoring of the circuit.
- Some types of specialized CSU (called a "drop-insert" CSU) also allow the insertion of one or more DSO's sourced from other equipment and services in the BTS, such as base station alarms and CDPD radios.

### BTS Line Card

Otherwise known as the terminating equipment or TE, the BTS line card handles the command, control, voice, and data signals from the BTS system and the MSC. It is responsible for framing and formatting the DSOs into the T1 structure on the transmit side, and receiving the same.

Also, it is important to note that many base stations may have more than one T1 link in the backhaul; however, the number of T1 circuits is dependent upon the traffic load of the site – the amount of traffic that must be carried back to the MSC.

### Testing T1 Circuits

T1 testing is critical to maintaining the network so it can operate at maximum efficiency. Maintenance and monitoring testing can be categorized in either of two ways: in-service performance monitoring and out-of-service testing.

#### In-service Performance Monitoring

In-service monitoring allows you to take a measure of network performance while live-traffic data is still present on the T1 circuit. Once T1 spans are commissioned and begin carrying live traffic, there is usually great reluctance to interrupt revenue-generating traffic to send known test patterns to check circuit performance. If out-of-service testing is required, it is often scheduled to occur at off hours to minimize impact to customers, although burdening the technicians with late-night testing forays. Since in-service monitoring does not disturb the T1 traffic, it can be performed at any time, under any traffic conditions, and so this method is more widely used for routine maintenance and monitoring. It also allows measurements to be performed on the T1 spans under actual operating conditions. The downside to this method of testing is that the measurements may not be as precise as those available for out-of-service testing. Monitoring live data allows technicians to detect alarms, bipolar violations (BPs), and frame errors. However, bit errors cannot be directly measured. Bit errors may be estimated by measuring CRC errors if the line is using ESF framing, or Frame errors can provide a very rough estimate of the bit error rate. As previously mentioned, the CRC block error estimation used in ESF framing format is about 98 percent accurate in detecting bit errors.

#### Out-of-Service Testing

Out-of-service testing is just as it sounds: you take the line out-of-service – removing live traffic from the T1 circuit – before testing can begin. Taking the line out of service generally requires coordination with network technicians as well as with MSC operators, both of whom will observe alarms when you take the span "down." With the line out-of-service, a test instrument transmits specific data patterns in place of the live BTS traffic. A receiving instrument is programmed to receive the same bit pattern sequence being sent. The receiver looks at the incoming pattern and counts a bit error for every received bit that is different from the programmed bit pattern. The receiver also looks for other errors and alarms, which are described later in this application note.

## T1 Network Technology

### ► Primer

There are several ways to perform out-of-service testing – either point-to-point with test instrumentation at both ends of the T1 span, or by creating a loopback at the far end of the span and using a single instrument to measure the round-trip performance of the T1 line. These two methods are depicted in Figure 10. For out-of-service testing, both point-to-point and loopback testing allow detailed performance measurements on any T1 circuit.

In general, point-to-point testing is considered to be a better practice, but it requires two test instruments and two operators – one at either end of the T1 circuit – to complete the testing. Loopback testing only requires a single test instrument and operator, so it is convenient and more efficient than point-to-point testing. However, the downside to loopback testing is that it can only analyze the combined performance of both the

transmit and receive paths at the same time; *it cannot easily distinguish on which side the problem exists.*

Since communications paths cannot normally be taken out of service for an extended period when a problem appears, fast and accurate diagnostics are important. For leased lines, a rapid answer to the question of who is responsible for clearing the fault is also important. Out-of-service testing provides the best diagnostic capabilities for locating the nature of the problem. However, it should only be used when serious errors are discovered when performing in-service monitoring of live traffic, or when installing new circuits, because it requires you to interrupt revenue-generating service for the duration of the testing.

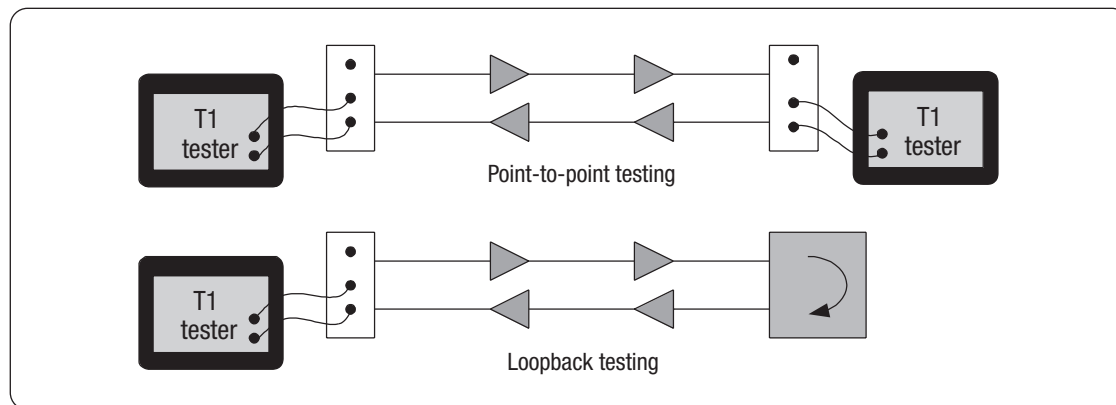

► **Figure 10:** Out-of-service testing methods

## Basic T1 Measurements

A few basic measurements are generally used for installation, maintenance, and troubleshooting T1 circuit problems. Some measurements are available in-service, while others are only available out-of-service. It is important to note which measurements are available in which testing method and to match those to the needs of your testing.

### Frame Errors

This measurement indicates the number of times a wrong bit value is observed in a framing bit position (refer to "T1 Framing Formats" for more information), and can also provide a primitive indication of the bit error rate. Frame errors can be measured both in-service and out-of-service. When observed for a long period of time, frame errors can provide a reasonable approximation to the bit error rate. Measure frame errors only examining every 193rd bit, so the observation period is on the order of hours or days, not minutes, to get this approximation. Another problem with simply measuring frame errors is that some network equipment, notably DACS and multiplexers, corrects frame errors instead of passing them through. This allows frame errors to be isolated within sections of the overall link, but can prevent detection of end-to-end problems if this type of equipment is present in the link.

### CRC Errors

CRC errors indicate the number of times the calculated CRC, based on the received data, does *not match* the CRC word sent from the transmitter on the far end. They provide a count of errors within a block (a 24-frame ESF block, in this case) of transmitted data, and therefore provide an approximate 98 percent accurate estimate of the bit error rate of the link. The CRC check can catch both single bit errors and burst errors. CRC errors can be monitored while the link is in-service, so you can do non-intrusive testing, without disturbing the live traffic. They may also be monitored in out-of-service testing. However, the CRC bits are only available when using ESF framing format, so if you have D4 framing on the line, you can't make this measurement. And, as with frame errors, some network equipment re-calculates the CRC before passing the data along through the network, so CRC errors may not be visible in end-to-end testing.

### Bipolar Violations (BPVs)

This measurement indicates the number of times the received signal violates the bipolar (*alternating* positive and negative pulses) rule; so the number of times that signals of the same polarity are consecutively

received. BPVs may be monitored both in-service and out-of-service. The BPV count is valid for both AMI and B8ZS line coding; the "intentional" BPVs sent in B8ZS line coding are NOT counted in this measurement, as long as the testing device is set for B8ZS line coding. The BPV count provides yet another indication of bit error performance, and can be monitored in-service without disrupting live traffic. BPVs are a good indicator of line quality problems such as repeater issues or line balance problems. However, some network elements – specifically those that may change the physical transmission media, such as fiber and microwave elements – may remove BPVs before re-transmission, so BPVs are usually only useful when looking at copper transmission pairs.

### Bit Errors

Bit errors provide a measurement of the number of times the received bit pattern does not match the transmitted bit pattern – errors representing incorrect data in the incoming bit stream, which affect quality-of-service. This measurement gives a definitive, accurate measure of the transmission quality. It gives the number of bit errors (also presented as a Bit Error Rate, or BER) received on the T1 link. However, in order to get an accurate measurement, you must take the line out-of-service so you can transmit a known bit pattern. The receiver must also know this bit pattern in order to measure the difference between transmitted and received bits. Different data patterns can stress different equipment along the line, so you may choose from a host of pre-defined bit patterns. These patterns, and their uses, are discussed in the next section. One shortcoming of BER testing, although a minor one, is that since you must take the line out of service, the measurement does not represent the error rate under actual live-traffic conditions. But if you have a problem that is affecting service, BER testing is the most effective troubleshooting tool.

### Errored Seconds

Errored seconds are a measure of circuit performance that is often used as a quality of service metric for tariffed lines. An errored second is defined as a one-second period during which any of the above listed errors, such as Bit Errors, CRC Errors, BPVs, or Frame Errors, occurred. Telcos will typically have a limit defined for errored seconds within a particular time period that will qualify as trouble.

# T1 Network Technology

► Primer

## BER Stress Test Patterns

A number of pre-defined patterns – strings of ones and zeros – are available for out-of-service testing of T1 circuit performance. This section

should help you understand which patterns to choose for your testing and may also help you understand why one pattern may show no errors while another pattern will fail with errors.

**Table 2: BER Test Patterns**

Pattern Name	What it is	Features/Pitfalls	Why you should use it
QRSS	Quasi-Random Signal Source is a PRBS that is based on a 20-bit shift register, and it generates every possible combination of ones and zeros (of 20 consecutive bits), and repeats every 1,048,575 bits, or about 1.5 times a second. Strings of zeros longer than 14 are suppressed so it doesn't violate ones density requirements. Very commonly used because it imitates live-traffic data and contains an average ones density of approximately 50%.	<ul style="list-style-type: none"> <li>Imitates live-traffic data</li> <li>Contains both high and low ones density sequences</li> <li>Uses rapid transitions between densities.</li> <li>Forces B8ZS substitutions in B8ZS provisioned equipment</li> </ul>	<ul style="list-style-type: none"> <li>Simulate live-traffic conditions</li> <li>Stress Line Equalizers</li> <li>Stress Timing Recovery related to excess zeros</li> </ul>
All Ones	A pattern that contains all ones. The only zeros that will appear in the data stream will be in the framing bits of a framed all-ones signal. When transmitted unframed, this signal may be recognized as an Alarm Indication Signal (AIS). In framed signals, this often is used as the "idle" pattern for circuits not in service.	<ul style="list-style-type: none"> <li>Contains maximum ones density, so it forces repeaters to draw their maximum current</li> <li>Does NOT force B8ZS substitutions in B8ZS provisioned equipment</li> </ul>	<ul style="list-style-type: none"> <li>Stress repeater powering system</li> <li>For measuring signal level power</li> </ul>
All Zeros	This pattern contains all zeros. The only ones that will appear in the data stream are in the framing bits of a framed all-zero signal.	<ul style="list-style-type: none"> <li>Violates ones density and excess zeros limits.</li> <li>Forces B8ZS substitutions in B8ZS provisioned equipment</li> <li>Forces LOS in AMI provisioned equipment, should NOT be used in AMI-provisioned lines</li> </ul>	<ul style="list-style-type: none"> <li>Verify that all circuit elements are correctly provisioned for B8ZS line coding</li> <li>Test for "clear channel" capacity</li> </ul>
1 in 8 (also called 1:7)	An eight-bit pattern that contains a single one. Maintains ones density and does not violate consecutive zeros requirements. Pattern is: 0100 0000	<ul style="list-style-type: none"> <li>Contains minimum ones density</li> <li>Forces B8ZS substitution in framed signals (when framing bits are zeros, there are 8 consecutive zeros) for B8ZS provisioned equipment</li> </ul>	<ul style="list-style-type: none"> <li>Stress Timing Recovery – ones density. Use this after 3 in 24 to determine if the problem is from a low ones density</li> </ul>
2 in 8	This is an 8-bit pattern that contains two ones and 6 zeros. It has a maximum of 4 consecutive zeros. The bit pattern is: 0100 0010	<ul style="list-style-type: none"> <li>It can help detect mis-provisioned B8ZS equipment on an AMI-only line. If QRSS or 3-in-24 patterns have errors, and this one doesn't, it may indicate a possible line code mismatch.</li> </ul>	<ul style="list-style-type: none"> <li>Can help detect B8ZS optioned equipment on an AMI-only line</li> </ul>
3 in 24	Contains three ones in a 24-bit repeating sequence. Contains 15 consecutive zeros, so it violates excess zeros requirement, but still has 12.5% ones density. Pattern is: 0100 01000 0000 0000 0000 0100	<ul style="list-style-type: none"> <li>Contains the minimum ones density, and max. number of consecutive zeros.</li> <li>Forces B8ZS substitutions in B8S provisioned equipment</li> <li>Forces Excess Zeros alarm</li> </ul>	<ul style="list-style-type: none"> <li>Stress Repeaters</li> <li>Stress Timing Recovery – both ones density and excess zeros</li> </ul>

**Table 2: BER Test Patterns (continued)**

Pattern Name	What it is	Features/Pitfalls	Why you should use it
T1-1 (Min/Max)	This is a 72-octet (byte) pattern that generates rapid transitions from low ones density to high ones density (minimum density to maximum density, hence min/max). When this is aligned to framing, it evenly fills three frames per sequence.	Contains minimum ones density and maximum ones density, with rapid transitions between them  Forces B8ZS substitutions in B8ZS provisioned equipment	Test preamplification, receive equalizers, and Automatic Line Build Out (ALBO) circuits in repeaters
T1-2 (Trip Test)	This pattern contains 96 octets consisting of a long series of high ones density octets followed by rapid changes from average ones density to low density octets. When this is aligned to frame boundaries, it fills 4 complete frames per sequence. This pattern meets the ones density criteria.	Contains minimum ones density and maximum ones density, with rapid transitions between them  Can simulate faulty framing Ft bits in D4 format – do NOT use with D4 framing.  Forces B8ZS substitutions in B8ZS provisioned equipment	Test M12 cards in DS3 multiplexing equipment
T1-3	This pattern contains 54 octets, again with high and low ones density and rapid transitions. It does NOT align to frame boundaries, so framing bits will rotate through the pattern sequence. This will create strings of 16 zeros, which violates the ANSI T1.403 consecutive zeros requirement.	Framed pattern has 16 consecutive zeros, so it violates ANSI ones density requirements. For this reason it should NOT be used in public T1 switched networks, but only on repeatered spans.  Forces B8ZS substitutions in B8ZS provisioned equipment	It stresses a repeater's ALBO and equalization circuitry.
T1-4	This is a 120-octet pattern designed to stress the equalization circuits between T1 muxes. Similar to T1-2, it contains rapid changes from high ones density to low ones density. When aligned to the frame, it fills 5 frames in one sequence.	Contains a maximum of 7 consecutive zeros, but with framing bits can force B8ZS substitution	Stress equalization circuits between T1 muxes
T1-5	This is a 53-octet pattern again designed to test the ALBO and equalization of repeater circuits. The pattern contains changes from high ones density to low ones density. The pattern does not evenly fill framing boundaries, so the framing bits rotate through the pattern, failing the ones density requirements.	Forces B8ZS substitutions in B8ZS provisioned equipment  Fails ones density requirements	It stresses a repeaters ALBO and equalization circuitry.
T1-6 (55 octet)	This is a 55-octet pattern that contains rapid changes between low and high ones density. It does not evenly fill frame boundaries, and so the framing bits rotate through the pattern sequence. This causes 16 consecutive zeros, and thus violates the excess zeros requirement.	Framed pattern has 16 consecutive zeros, so it violates ANSI ones density requirements. For this reason it should NOT be used in public T1 switched networks, but only on repeatered spans.  Forces B8ZS substitutions in B8ZS provisioned equipment	It stresses a repeaters ALBO and equalization circuitry, but also timing recovery.

## T1 Network Technology

► Primer

### The Simplified DSX-1 Patch Panel

The DSX-1, or digital cross-connect level 1, patch panel is a device that is commonly wired in-line in T1 links. It offers the technician easy access to patch in test equipment for either in-service or out-of-service testing, without having to disturb the physical copper-pair wires. These panels are commonly used wherever T1 links are used, in COs, MSC switch bays, and BTS installations. The DSX-1 is depicted in Figure 11 below. There are several components that need description.

The wiring posts, depicted in Figure 11 as square-post terminals, are used for hard-wiring the connections through the panel, so when not used in a testing mode, signals pass through undisturbed. When testing plugs are inserted into the jacks, the "through" connection is broken, and the signal from the jack is connected instead, with the exception of the monitor jack, which does not disturb the through connection. These are "break-before-make" connections when equipment is plugged into the jacks.

The **MON jack** access allows in-service monitoring of the signals. This jack is isolated from the signal through resistors, so plugging in to this

jack does not disturb the "through" signal. The resistors that isolate from the through signal also attenuate the signal by about 20 dB, so this is also referred to as the "20 dB down port." If properly wired, the **Trace** lamps will both illuminate when you plug in to either monitor jack, allowing you to locate the "other" side of the cross-connect.

The **IN jack** name may be somewhat confusing, since as you can see, the IN jack connects to the Rx port of the digital equipment on either side of the panel. However, when "patching in" test equipment, the tester Transmit output is connected to the IN jack to drive the digital equipment Rx, disconnecting the signal from the far-side digital equipment Transmitter. It's easy to remember if you take the vantage point of the test equipment – the tester transmitter goes IN to the equipment Rx.

Likewise, the **OUT jack** name may be confusing. But again, from the test equipment perspective, the tester Rx gets the OUT signal from the digital equipment transmitter. Connecting into this jack connects the transmitter from the digital equipment OUT to the test equipment Rx.

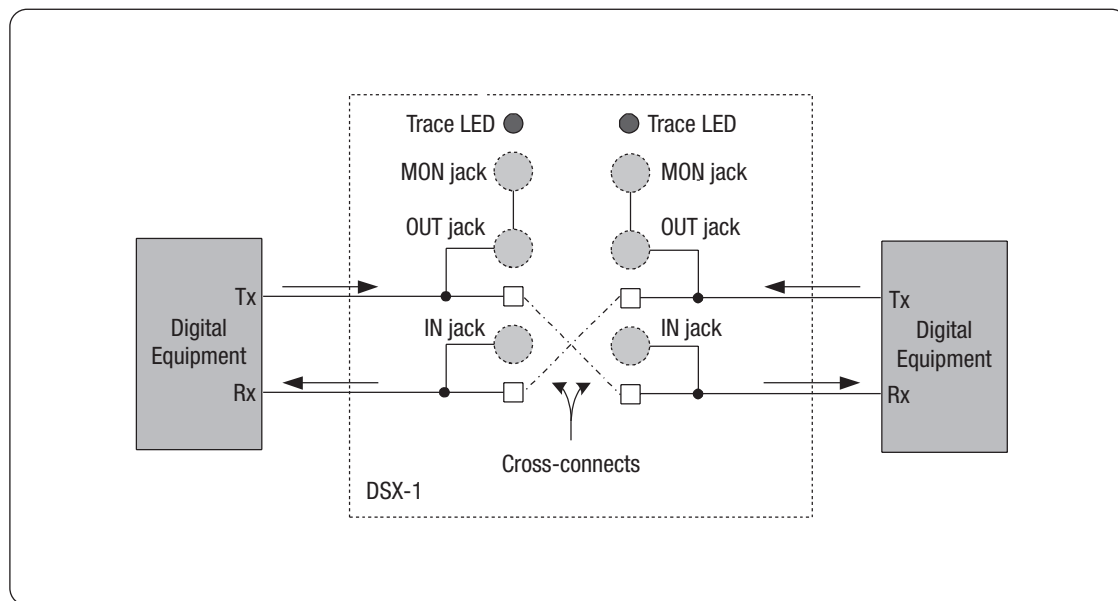

► **Figure 11:** The DSX-1 Patch Panel

**Appendix A: Glossary and Acronyms** III, V**AIA Alarm Indication Signal**

A signal transmitted in place of the normal signal to maintain transmission continuity and to indicate to the receiving equipment that there is a transmission problem located either at the equipment originating the AIS signal or upstream of that equipment

**AMI Alternate Mark Inversion**

A line code that uses a ternary (three level) signal to convey binary digits in which successive binary ones ("marks" or pulses) are of alternating polarity, either positive or negative, equal in amplitude. A binary zero ("space") is transmitted as no pulse, or zero amplitude. North American implementations use signal elements representing binary ones that are non-zero for only half the bit interval period

**ANSI**

American National Standards Institute

**Backhaul**

Term used to commonly refer to digital transmissions carrying signals from the Base Transceiver Station (BTS) sites "back" to the Mobile Switching Center (MSC) in the networks of wireless operators

**BER**

Bit Error Rate: A measure of transmission quality expressed as a ratio. It is the number of wrong bits received divided by the total number of bits received, and is often expressed as a negative exponent. For example, "10 to the -8" indicates one in 100 million bits (1 of 100,000,000) are in error.

**BERT**

Bit Error Rate Test. A test in which a known pattern is transmitted across a medium to a receiver programmed with the same pattern. The receiver looks at the incoming pattern and counts a bit error for every received bit that is different from the programmed bit pattern. Data is presented as a BER.

**Blue Alarm**

Refer to AIS

**BPV Bipolar Violation**

In a bipolar signal, a one (mark or pulse) that has the same polarity as the previous one (mark or pulse)

**B8ZS**

Bipolar with 8-zero Substitution. A coding scheme in which the transmitter "substitutes" a fixed pattern of ones, zeros, and BPVs in place of 8 consecutive zeros. This is a very specific pattern, each block of eight consecutive zeros is replaced with 000VBOVB, where B represents and inserted "1" bit, and V represents an inserted "1" that is a bipolar violation

**BTS**

Base Transceiver Station

**Carrier**

An organization that provides telecommunications service to the public.

**Channel**

A channel is defined as one or more digital time slots established to provide a communications path between a message source and its destination.

**Channelized**

Payload digit time slots are assigned in a fixed pattern to signal elements from more than one source, each operating at a slower digital rate. See TDM.

**CDPD**

Cellular Digital Packet Data. A set of protocols for transmission of packetized data over cellular networks, transmitting data at 19.2 kbps. Packetized data is transmitted over idle 30 kHz carrier channels without disrupting voice traffic or requiring additional bandwidth.

**Churn**

Customer turnover – changing carriers, usually implies rapid changes and low consumer loyalty

## T1 Network Technology

► Primer

### Clear channel

A characteristic of a DS1 transmission path in which the 192 "information" bits in a frame can represent any combination of zeros and ones without restrictions. This allows for direct transmission of data to Europe, and for creation of large concatenated "pipes" of data. In North America, two long-standing problems have impeded clear-channel capabilities, but may be resolved through:

- Complete end-to-end out-of-band signaling, achieved through the SS7 network and ESF framing.
- B8ZS line coding, allowing users to send any type of information within the DS0, including long strings of zeros.

### CO

Central Office. Local Telco office within the PSTN that terminates subscriber lines, and through which the T1 networks may be routed.

### CRC

Cyclic Redundancy Check. A field used to detect errors in blocks of data transmitted across communication links. The detection is determined by a formula applied at both the transmit and receive ends.

### CSU

Channel Service Unit. A customer-owned, physical layer device that provides framing, coding, and facility equalization functions, as well as performance monitoring and history reports on the T1 links in both transmit and receive directions. The CSU connects customer equipment (the BTS line card) to the Telco's digital transmission equipment (the NIU), and is responsible for maintaining a high-quality, synchronized signal at either interface.

### D4

Refer to Superframe

### DACS

Digital Access Cross connect System. Transmission equipment which is used to re-arrange the channels which are assigned to particular time slots between the incoming and outgoing digital transmission signals. This device essentially performs a switching function with the input / output relationships assigned through an administration function (SW control).

### DS0

Digital Signal, level 0. A digital signal transmitted at the nominal rate of 64 kbps

### DS1

Digital Signal, level 1. A digital signal transmitted at the nominal rate of 1.544 Mbps. Usually provisioned to carry 24 DS0-level signals.

### DS3

Digital Signal, level 3. A digital signal transmitted at the nominal rate of 44.736 Mbps. Usually provisioned to contain 28 DS1-level signals.

### DSX

Digital Cross-connect. a manual cross-connect point that primarily serves as a test access point for DS1 signals and for substituting operational equipment when necessary.

### ESF

Extended Super Frame. A framing format employed in T1 systems consists of twenty-four consecutive T1 frames (each T1 frame containing 24 DS0s). This format provides FPS bits for framing, CRC bits for error checking, and FDL bits for maintenance signaling information out-of-band from payload data.

### Frame

On digital transmission facilities in the telephone network, the digital bit stream is organized into fixed units, called frames, which are transmitted 8000 times per second, or every 125 microseconds. A frame typically consists of a block of data with one time slot from each channel plus synchronization and other overhead bits.

### FDL

Facility Data Link. Refer to ESF.

### Grooming

A term commonly used to describe the activity of removing idle or unused channels from the transmission paths, combining and forwarding only the channels / slots that are assigned for use. This is only effective when large numbers of lines are muxed together into larger "pipes," such as combining a large number of T1s into DS3 channels. Bandwidth can be conserved, using fewer or a single DS3, if the unused or unassigned DS0s or DS1s are removed from the transmission.

### In-band

Using or involving the information digit time slots of a DS1 frame, exclusive of the framing bit; i.e., payload data.



**ISUP**

Integrated Systems Digital Network (ISDN) User Part. SS7 protocol that defines messages, protocol, and procedures for call setup and tear-down for circuit-switched calls.

**LAPD**

Link Access Protocol – D channel. A protocol used in ISDN systems, defined by ITU standard Q.921.

**LBO**

Line Build Out. An electrical network used to simulate a length of cable.

**Line Repeater**

See Repeater

**LOF**

Loss of Framing

**Loopback**

A state of a transmission facility in which the received signal is returned towards the sender.

**LOS**

Loss of Signal – indicated by a blue alarm, or AIS in T1 terms.

**M13**

A multiplexer in the digital hierarchy that multiplexes 28 DS1 signals into a single DS3 signal. A duplex device, this also performs the demux function as well.

**MDF**

Main Distribution Frame. The main wiring frame within a Telco CO.

**MSC**

Mobile Switching Center. The switching control interface for the mobile network base stations, and interface with the PSTN

**Mux**

Multiplexer. Equipment that aggregates two or more channels onto a single transmission facility, where each channel takes a constant, determined space. For example, a T1 mux takes in multiple DS0s and "muxes" them into a T1.

**NCTE**

Network Channel Terminating Equipment. Equipment that originates or terminates signals at the specified rate. Typically the endpoint in a transmission system.

**NIU**

Network Interface Unit. Considered the demarcation point between the network and the customer premises. The primary function of the NIU is to provide signal regeneration, DC isolation from the network to the customer premise, loopback capabilities for network testing. It is often referred to as a "smartjack" because it provides loopback capabilities and can collect and return performance data to the Telco central office.

**Ones Density**

Refer to Pulse Density

**Payload**

The 192 information bits of a DS1 frame

**PCM**

A technique that converts analog voice and data into a digital bit stream. The amplitude of the analog signal is sampled 8000 times per second, and the sample is converted to an 8-bit value. North American systems use a non-linear encoding scheme ( $\mu$ -law) to preserve fidelity within the 8-bit slot.

**PRI**

ISDN Primary Rate signal. A 1.544 Mbps channelized DS1 with one channel assigned to carry LAPD protocol messages for call control and maintenance signaling – the D-channel, and 23 channels assigned for bearer (user) data – the B-channels.

**PSTN**

Public Switched Telephone Network

**Pulse Density**

A measure of the number of "ones" (marks, pulses) in relation to the total number of bit time slots transmitted.

**QRSS**

Quasi-Random Signal Source. A pseudo-random binary sequence (PRBS) that is based on a 20-bit shift register, generates every possible combination of ones and zeros (of 20 consecutive bits), and repeats every 1,048,575 bits, or about 1.5 times a second in T1 applications. Strings of zeros longer than 14 are suppressed so it doesn't violate ones density requirements.

**RAI**

Remote Alarm Indication. A signal transmitted from terminal equipment in the outgoing direction when it determines that it has lost the incoming signal, or when it receives an AIS signal in the incoming direction. RAI is also called the Yellow Alarm.

## **T1 Network Technology**

► Primer

### **Repeater**

A bi-directional device in a full-duplex transmission facility that recovers, reconstructs, and retransmits the received signal. Usually powered from the line. Sometimes referred to as a regenerator.

### **SF**

Refer to Superframe

### **Superframe**

A framing format consisting of twelve consecutive frames employed in T1 networks, also referred to as D4 framing. The D4 Superframe format is a structure in which the F (frame) bits are used for framing alignment only. In this format, the F bits are actually divided into two groups:  $F_T$  bits are used exclusively to identify frame boundaries;  $F_S$  bits, and may be used to identify frames that carry signaling

### **TDM**

Time Division Multiplexing. The process of assigning channels to a time slot within a data stream

### **Telco**

Telephone Company – a local exchange carrier.

### **TE**

Terminal Equipment. Equipment that originates or terminates signals at the specified rate. Typically the endpoint in a transmission system.

### **Short haul**

For T1 communications, short haul is defined as signals transmitted up to 650 feet through 22 gauge ABAM cable.

### **Smartjack**

Refer to NIU

### **Yellow Alarm**

Refer to RAI

**References:**

- I Telecommunications Research Associates (TRA) glossary  
*Emerging Technologies* 1995.
- II Roland Keifer,  
*Test Solutions for Digital Networks*, 1997
- III Committee T1 – Telecommunications, Report No. 25.  
*A Technical Report on Test Patterns for DS1 Circuits*, November, 1993
- IV Jack Dempsey,  
*Telecom Basics*, 1988
- V ANSI T1.403-1995  
*Network-to-Customer Installation-DS1 Metallic Interface*

tektronix.com

**Contact Tektronix:**

**ASEAN Countries & Pakistan** (65) 6356 3900

**Australia & New Zealand** (65) 6356 3900

**Austria** +43 2236 8092 262

**Belgium** +32 (2) 715 89 70

**Brazil & South America** 55 (11) 3741-8360

**Canada** 1 (800) 661-5625

**Central Europe & Greece** +43 2236 8092 301

**Denmark** +45 44 850 700

**Finland** +358 (9) 4783 400

**France & North Africa** +33 (0) 1 69 86 80 34

**Germany** +49 (221) 94 77 400

**Hong Kong** (852) 2585-6688

**India** (91) 80-2275577

**Italy** +39 (02) 25086 1

**Japan** (Sony/Tektronix Corporation) 81 (3) 3448-3111

**Mexico, Central America & Caribbean** 52 (55) 56666-333

**The Netherlands** +31 (0) 23 569 5555

**Norway** +47 22 07 07 00

**People's Republic of China** 86 (10) 6235 1230

**Poland** +48 (0) 22 521 53 40

**Republic of Korea** 82 (2) 528-5299

**Russia, CIS & The Baltics** +358 (9) 4783 400

**South Africa** +27 11 254 8360

**Spain** +34 (91) 372 6055

**Sweden** +46 8 477 6503/4

**Taiwan** 886 (2) 2722-9622

**United Kingdom & Eire** +44 (0) 1344 392400

**USA** 1 (800) 426-2200

For other areas contact Tektronix, Inc. at: 1 (503) 627-7111

Updated 8 February 2002

**For Further Information**

Tektronix maintains a comprehensive, constantly expanding collection of application notes, technical briefs and other resources to help engineers working on the cutting edge of technology. Please visit [www.tektronix.com](http://www.tektronix.com)

Copyright © 2002, Tektronix, Inc. All rights reserved. Tektronix products are covered by U.S. and foreign patents, issued and pending. Information in this publication supersedes that in all previously published material. Specification and price change privileges reserved. TEKTRONIX and TEK are registered trademarks of Tektronix, Inc. All other trade names referenced are the service marks, trademarks or registered trademarks of their respective companies.

04/02 FLG5614/PGI

2GW-15658-0



**Tektronix**  
Enabling Innovation